

## MC60 P/I Transmitter

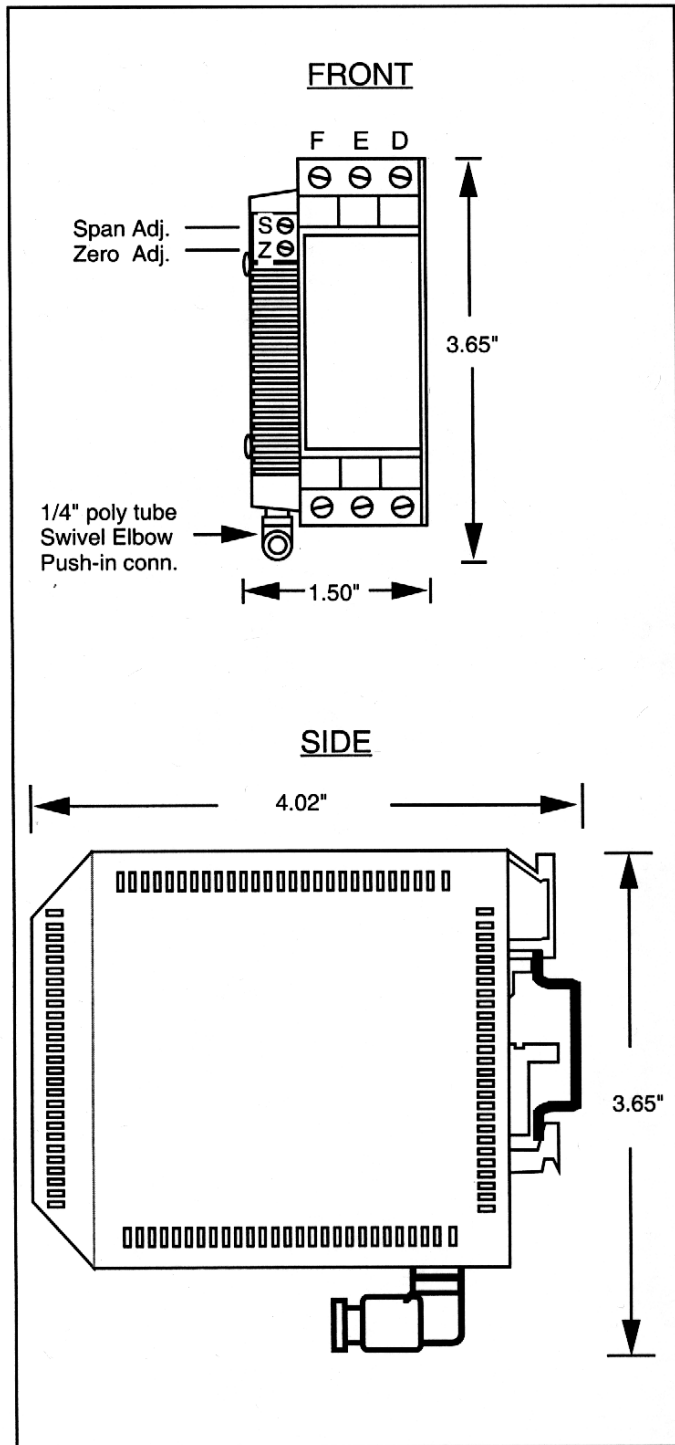

### GENERAL DESCRIPTION:

The Model MC60 P/I Transmitter is a Din Rail mounted solid state pressure to electric converter. It converts a pneumatic signal, within the ranges given below, to a 4-20 mA two wire output signal. Span and zero calibration adjustments are easily accessible through the front case. The 4-20 mA loop output can be readily monitored from the test terminals on top of the unit.

### SPECIFICATIONS:

**Inputs:** Pneumatic signal ranges, PSIG  
0-5, 0-10, 0-15, 0-30

**Overpressure:** 3X Rated

**Power:** 24 to 40 VDC

**Output:** 2-Wire, 4-20 mA

**Maximum Load:** @ 24 VDC - 550 ohms  
@ 40 VDC - 1350 ohms

### Accuracy:

**Linearity** - .2% of span

**Repeatability** - .05% of span

**Hysteresis** - Negligible

**Temperature** - Maximum shift  $\pm$  1% of span over the temperature compensated range

**Operating Temp. Range:** 0 to 250 degrees F  
(-17.8 to 121.0 deg. C)

**Compensated Temp. Range:** 32 to 120 deg. F  
(0 to 48.9 deg. C)

**Span Adjustment:**  $\pm$  30% of range  
\*Low range of the 0-5 PSI Model is adjustable to 0-1.5 PSIG  
Full Scale

**Electrical Connections:** 2-wire screw-clamp terminal

**Housing:** Molded Grey Polyamide - DIN1 or 3 rail mount

### -HOW TO ORDER-

MODEL	PART NO.	RANGE	
		(XX)	PSI
MC60 P/I	50-196-XX	-05	0-05
		-10	0-10
		-15	0-15
		-30	0-30

# Installation: Model MC60 P/I Transmitter

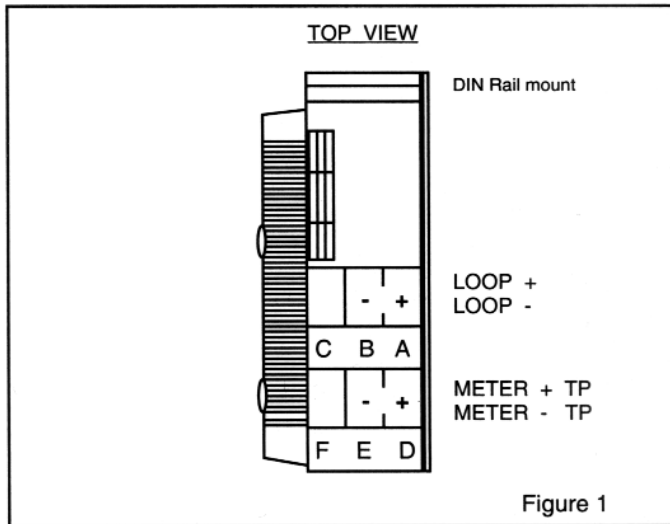

The Model MC60 P/I Transmitter is a solid state pressure to electrical converter that translates a pneumatic (pressure) signal into a 4-20 mA two wire output signal. Span and zero calibration adjustments are easily accessible through the front of the case. The 4-20 mA loop can be monitored at the test terminals without disconnecting the MC60 or creating a special hookup.

**Wiring Hookup.** (Fig. 1 & 2) For the MC60 to function properly it is necessary to hook up the incoming wires from the instrument loop with the correct polarity.

## CALIBRATION:

Your MC60 has been adjusted for ZERO and SPAN at the factory, however, if it becomes necessary to check or to reset these adjustments, proceed according to the following instructions.

Do not attempt to make any adjustment requiring pressurized air unless you have a precision regulator with clean, dry instrument air available.

With the electrical and pneumatic circuits operating connect a multimeter, to the test terminals, TP+ and TP- on the top of the unit. ( Fig. 1)

**Zero Adjustment:** Disconnect the pneumatic input from the sensor. (Fig. 3) When the input pressure is ZERO, the output (milliammeter) reading should be 4 mA.

If the current is more or less than 4 mA, adjust the **ZERO** trimmer until the current reads 4 mA. **DO NOT** make any adjustment to SPAN until you have completed the ZERO setting.

**SPAN Adjustment:** This adjustment will require that you furnish air pressure directly from precision air standard to the pneumatic input of the MC60. With the ZERO setting in place set the input pressure to the maximum pressure (5, 10, 15 or 30 PSI) as stated on the nameplate on the MC60. When this pressure is applied to the MC60, the milliammeter reading should be 20 mA. If it is not, adjust the **SPAN** trimmer for a milliammeter reading of 20 mA.

There will be some interaction between the ZERO and SPAN adjustments, so if you have readjusted the SPAN, recheck the ZERO setting. Readjust, and recheck SPAN until the readings are as near to 4 and 20 mA as possible.

It may be necessary to recheck the ZERO and SPAN settings several times to complete this adjustment.

